

MODEL 3350DX

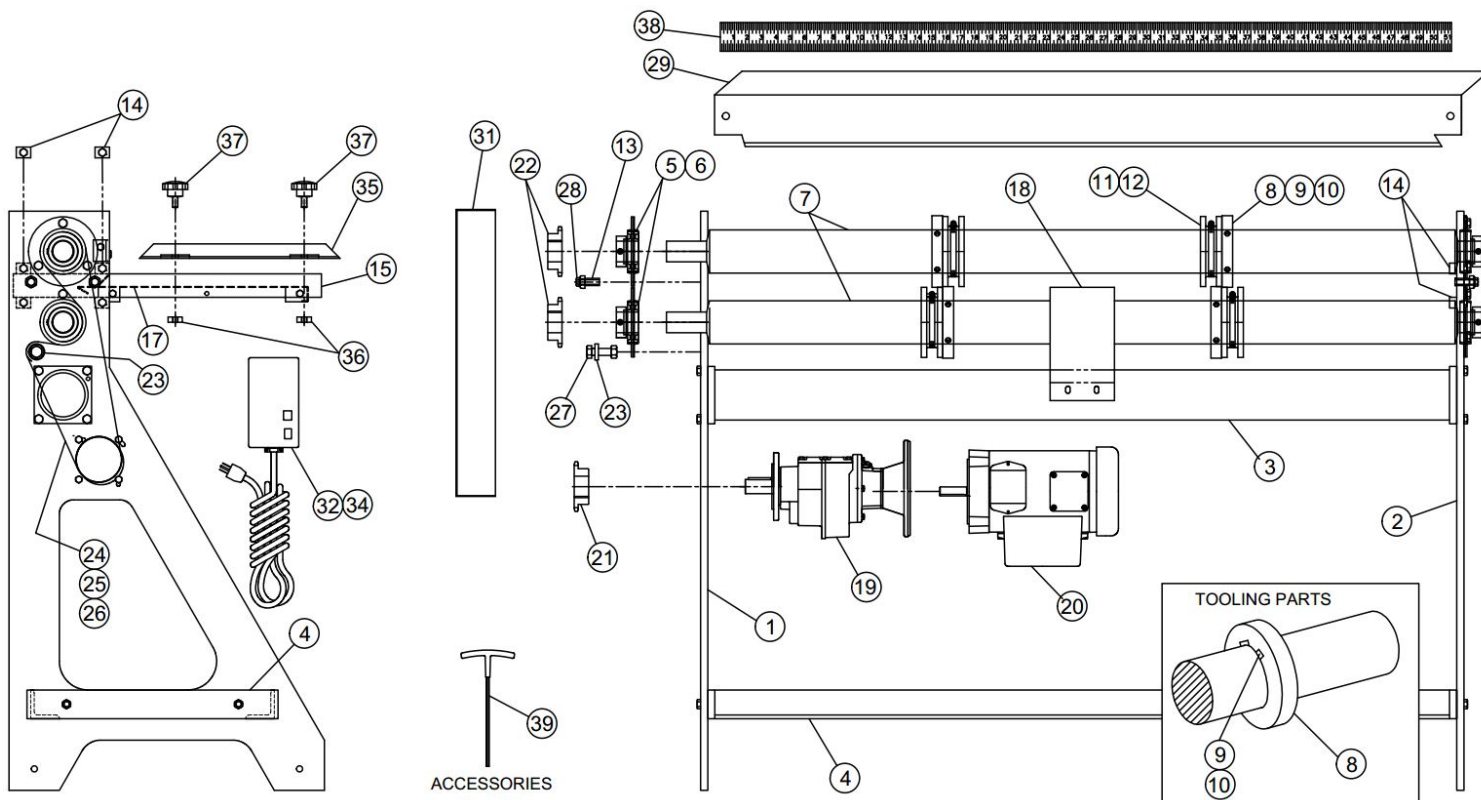

Key No.	Part No.	Description	Key No.	Part No.	Description
1	3350-P24-18V2	End Housing -Drive Side	21	200018	4020 x 1" Motor Sprocket (60 fpm)
2	3350-P24-18	End Housing -Idler Side	22	200017	4020 x 1- 7/16" Arbor Sprocket
3	290073	Torsion Tube Assembly	23	200003	1/2" ID Chain Idler Bearing
4	106689	Base Shelf Assembly	24	285048	No. 40 Chain x 87 links
5	200015	1- 7/16" Arbor Bearing	25	285049	No. 40 Chain Offset Link
6	200016	Bearing Flange (Req's 2 per bearing)	26	285050	No. 40 Chain Master Link
7	100021	Knife Arbor- 3"OD x 52" Face	27	*285026	Idler Bearing Bolt
8	200027	3" x 5" x 3/4" STD 52100 Alloy Knives	28	*275015	5/16" 18-N.C. Pull bolts
9	285022	234 Gib Key	29	100033	Finger Guard
10	285018	3/8-24 x 1/2" Half Dog Point Set Screw	31	106691	Chain Guard
11	203129	3" x 5" Stripper Ring (Red)	32	203100	Magnetic Starter G8290
12	285932	3" x 5" Clamp	34	200008	Electric Cord w/Plug
13	100421	Gauge Adjusting Bolt x 1.5"	35	106684	Adjustable Side Gage
14	106688	Guage Trap Block	36	106683	Clamp Block
15	100022	Side Gauge	37	202682	Reid DK-28 Plastic Knob
17	106682	Table Assembly	38	203132	Scale (mounts on Finger guard)
18	100024	Table Support	39	200011	3/16" T-Handle Allen Wrench
19	300308	Eurodrive Reducer			
20	300309	3/4 HP Motor			