



GARY MACHINERY LLC

1931 East Main Street
Griffith, IN 46319

Phone: 219/ 980-5700

FAX: 219/ 980-0405

INDUSTRIAL DUTY SLITTERS

Available In:
4", 5", 6" and 7" Arbor Size

4" Arbor Sheet Slitter

- 4" diameter hardened and precision ground arbors
- Arbors mounted in heavy duty tapered roller bearings
- 1 HP gear head drive package with arbors geared together
- Heavy duty 10 ga. metal base and guards
- 80 fpm operating speed
- Adjustable outboard squaring guide - manual adjustment
- 110/220/1ph electric
- 3 sets 46SK STD D2 slitter knives



Industrial Duty Features

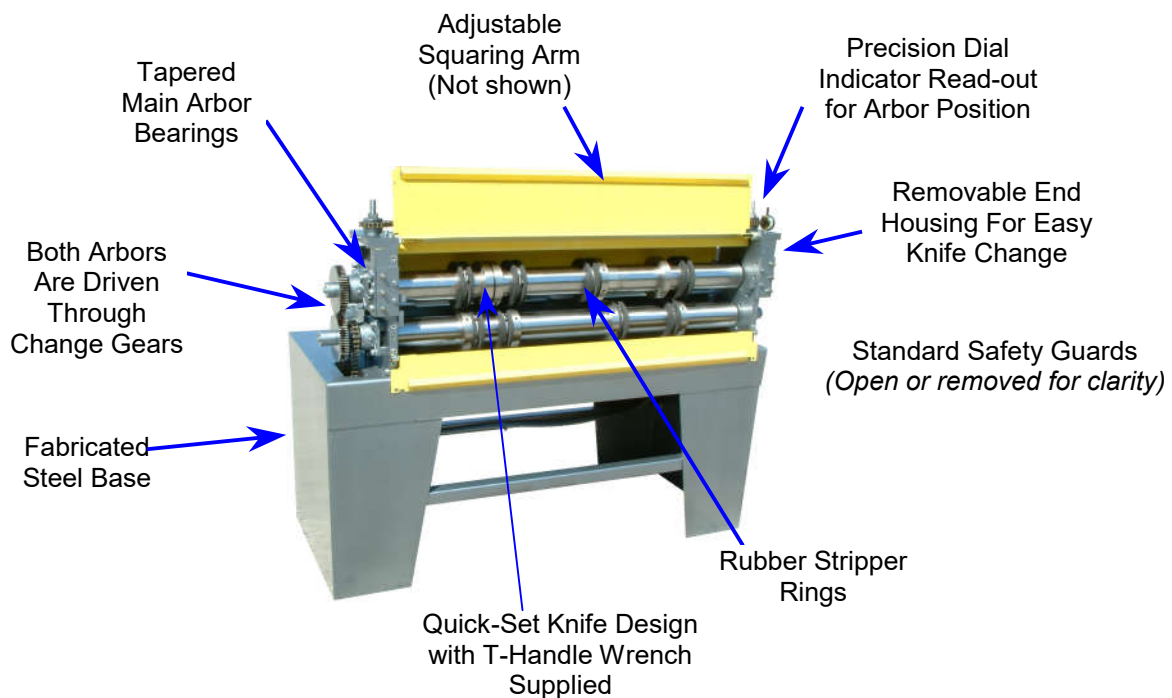

Slitter Specifications

Industrial Duty Model

	448	460	548	560	648	660
Overall Width	66"	77 ½"	66"	77 ½"	66"	77 ½"
Overall Depth	30"	30"	30"	30"	30"	30"
Overall Height	43 ½"	43 ½"	50"	50"	50"	50"
Shipping Weight	1300	1600	2200	2500	3000	3300
Max Sheet Width	49 ½"	61 ½"	49 ½"	61 ½"	49 ½"	61 ½"
Pass Line Height	38"	38"	38"	38"	38"	38"
Knife Arbor Diameter	4"	4"	5"	5"	6"	6"
Knife Dimensions	4" x 6" x 1"	4" x 6" x 1"	5" x 7" x 1 ½"	5" x 7" x 1 ½"	6" x 9" x 1 ½"	6" x 9" x 1 ½"
Motor	1 HP	1 HP	3 HP	2 HP	7 ½ HP	5 HP
Speed	80 fpm	80 fpm	100 fpm	100 fpm	100 fpm	100 fpm
Voltage	120V 1 ph. 60 Hz			240/480V 3 ph. 60 Hz		
Standards	Adjustable top arbor penetration via fine-thread screws with connecting chain with a dial indicator, hand wheel adjustable outboard squaring guide, T-handle Allen wrench, Three sets of knives and rubber stripper ring assemblies, Operating manual			Adjustable top arbor penetration via Jack Screws with a dial indicator, hand wheel adjustable outboard squaring guide, T-handle Allen wrench, Three sets of knives and rubber stripper ring assemblies, Operating manual		
Options	Extra tooling, Special tooling, Variable speed drives, Centering type entry guides, Passline rolls, Overrunning clutch, Air clutch/brake					

Slitter Capacities

(Number of cuts)

Thickness			Industrial Duty MODEL						
Ga.	In.	Mm.	448	460	548	560	648	660	672
30	.015"	.30	*	*	*	*	*	*	*
28	.018"	.37	*	*	*	*	*	*	*
26	.021"	.45	*	17	*	*	*	*	*
24	.027"	.60	*	13	*	*	*	*	*
22	.033"	.75	15	8	*	19	*	*	*
20	.039"	.91	10	5	*	13	*	*	21
18	.051"	1.2	5	3	13	7	*	19	12
16	.063"	1.5	3	2	8	5	*	12	7
14	.078"	1.8	1		3	2	14	8	5
12	.108"	2.6			1		6	4	2
10	.137"	3.4					2	1	

*Cutting capacity is limited by allowable number of knives on the machine.

SCAN ME



Use your smart phone to scan this and get information on our company and how to contact us!